

License: CERN Open Hardware Licence Version 2 – Permissive
 Source Code: <https://github.com/pedalboard/pedalboard-hw>

Sheet: /
 File: pedalboard-hw.kicad_sch

Title: Open Pedalboard

Size: A4	Date: 2023-03-12	Rev: 2.0.0
KiCad E.D.A. kicad-cli 7.0.1.1-36-gbcf78dbe24-dirty-deb11		Id: 1/4

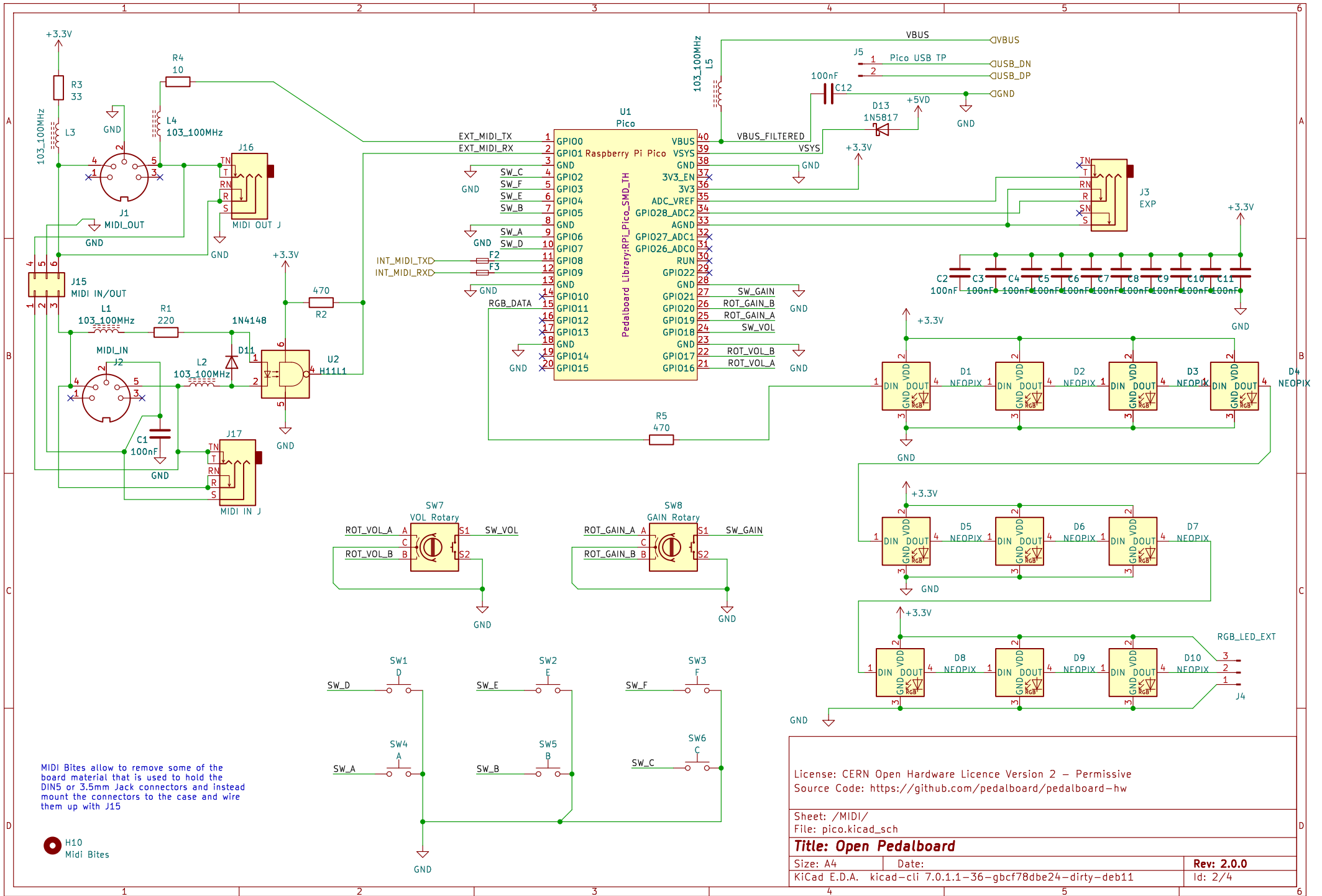

MIDI Bites allow to remove some of the board material that is used to hold the DIN5 or 3.5mm Jack connectors and instead mount the connectors to the case and wire them up with J15

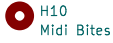

License: CERN Open Hardware Licence Version 2 – Permissive
 Source Code: <https://github.com/pedalboard/pedalboard-hw>

Sheet: /MIDI/
 File: pico.kicad_sch

Title: Open Pedalboard

Size: A4 Date:
 KiCad E.D.A. kicad-cli 7.0.1.1-36-gbcf78dbe24-dirty-deb11

Rev: 2.0.0
 Id: 2/4

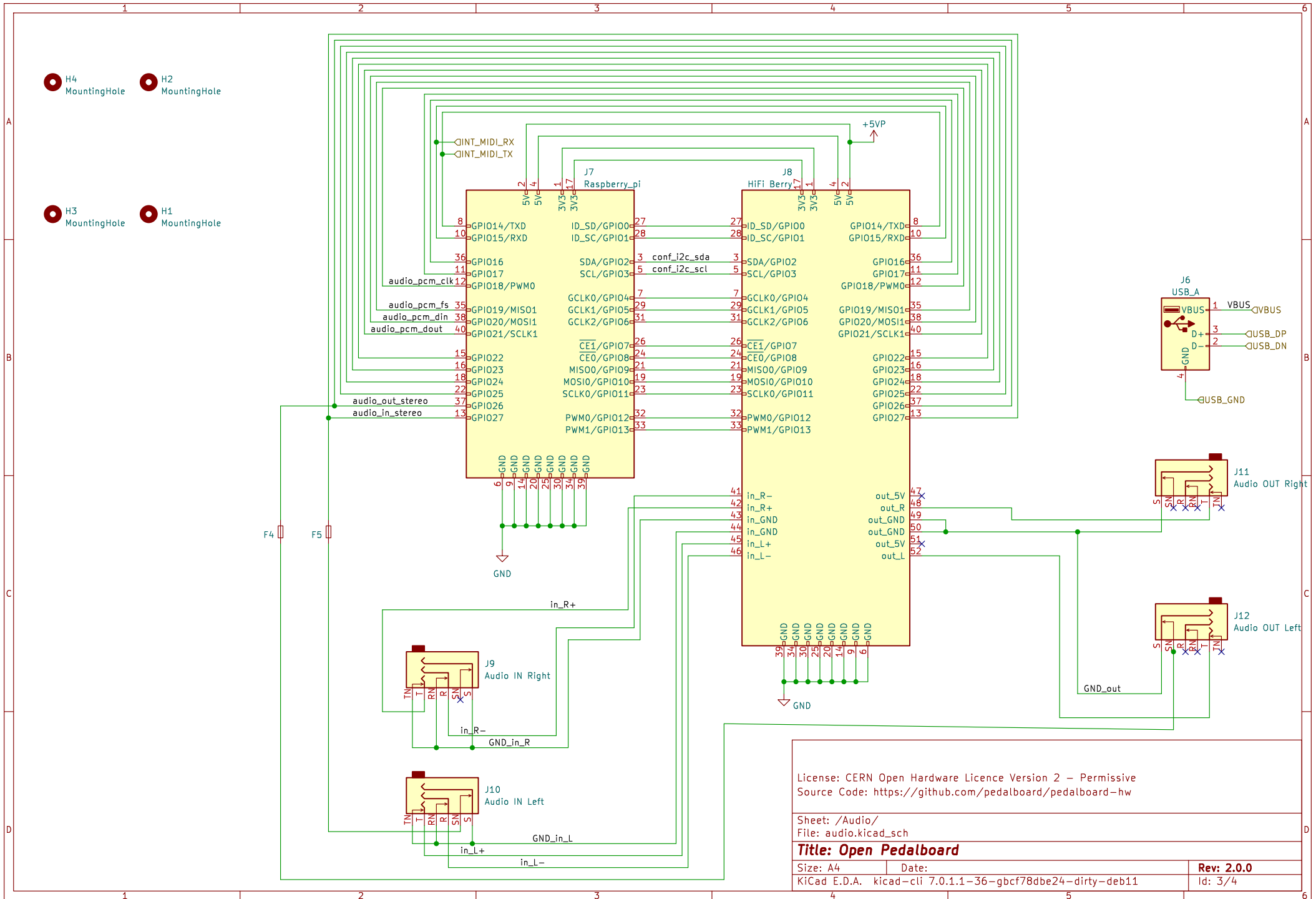

License: CERN Open Hardware Licence Version 2 – Permissive
 Source Code: <https://github.com/pedalboard/pedalboard-hw>

Sheet: /Audio/
 File: audio.kicad_sch

Title: Open Pedalboard

Size: A4 Date:
 KiCad E.D.A. kicad-cli 7.0.1.1-36-gbcbf78dbe24-dirty-deb11

Rev: 2.0.0
 Id: 3/4

5.5mm x 2.1mm, Center Negative.

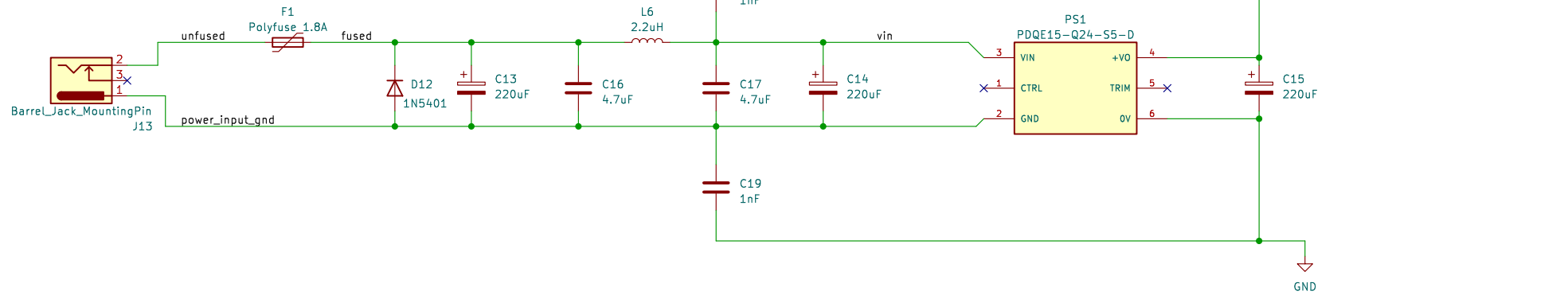

Larger value has the detrimental effect of causing greater ac leakage current between the input and the output of the power supply

CAUTION: Due to a limitation of the CM4 Pico A board the Jumper J14 must be removed when the CM4 is powered via USB!

EMC filter: <https://www.cui.com/blog/emi-filter-components-what-they-are-and-how-they-work>
CM Noise: <https://www.cui.com/blog/reducing-supply-rail-common-mode-noise-in-audio-applications>

License: CERN Open Hardware Licence Version 2 – Permissive
Source Code: <https://github.com/pedalboard/pedalboard-hw>

Sheet: /Power Supply/
File: psu.kicad_sch

Title: Open Pedalboard

Size: A4	Date:	Rev: 2.0.0
KiCad E.D.A. kicad-cli 7.0.1.1-36-gbcf78dbe24-dirty-deb11		Id: 4/4